

GB F SR Master series rack assembly instructions



WARNINGS/WARRANTY

WARNINGS

Read this manual carefully before using or servicing the racks. It must be kept carefully in a place known to the rack operators, supervisors, and staff charged with maintenance, repairs and final scrapping. This manual indicates the intended use of the racks and provides the installation, user and final scrapping instructions. It provides information on servicing the racks, ordering spare parts and any residual risks. This manual is an integral part of the racks and must be kept safely in the vicinity of the racks until the racks are finally scrapped. Request a new copy of the manual if it is lost. Make sure that all operators have understood the user instructions and the meanings of the symbols and tables on the racks themselves. Do not remove or damage the safety equipment, labels and texts, especially those required by law. This manual reflects the state of the art at the time of sale of the racks and cannot be considered inadequate only because they have been updated at a later date in the light of new experience. The manufacturer has the right to update the production and manuals without any obligation to update preceding production and manuals, unless in exceptional circumstances.

To request updates of the instruction manual and supplements, which are to be considered integral parts of it, contact the phone numbers given in this manual. FAMI requests, if you transfer ownership of the racks to a third party, that you ensure that they are accompanied by this User and Maintenance Manual, and report the name and address of the new owner to us to facilitate us in providing updates and supplements of the manual to them.

WARRANTY

FAMI guarantees its racks for a period of two years from the date of shipping, and for duty of one work shift a day. The warranty is recognised only if the racks have been installed and used properly in accordance with the instructions given in this manual, including the specified scheduled maintenance. FAMI may request the return of damaged parts when they are replaced. Any other technical work will be agreed by FAMI on a case by case basis. The warranty does not cover consumables and materials for scheduled maintenance, or parts damaged by improper use. Repairs and replacements covered by the warranty do not extend its term. The warranty excludes any demand for reimbursement due to loss of production.

INTENDED USE

The racks described in this manual are designed to be used for storing miscellaneous materials on the fixed or pull-out shelves and drawers.

If the installation of the racks results in the creation of passageways or aisles adjacent to them, the racks must be enclosed with steel panelling walls on all sides not used for picking the material; the aisles or passageways must have the following widths:

- Aisles used for picking or placing material with hand trucks, with or without pull-out shelving: width = depth of extracted shelf + 900 mm.
- Aisles used for staff passageways: minimum width 1250 mm.

Picking/placing aisles may not be used as staff passageways. Please contact FAMI for the specifications of aisles used by driven trucks. The racks may only bear **vertical forces** (fig. 1) which are applied by the fixed or pull-out shelves or drawers on the vertical members.

Do not apply horizontal or diagonal forces to the racks, by:

- resting ladders against them.
- applying loads outside the perimeter of the fixed shelves or the pull-out shelves and drawers.
- using the racks as a ladder (fig. 2).
- sitting on the fixed shelves of the pull-out shelves or drawers (fig. 3).

The racks are not suited for storing the following materials:

acid/noxious/flammable/explosive substances or unpacked food products. Using the racks in any way other than indicated in this manual relieves FAMI of any and all liability for consequential damage or injury.

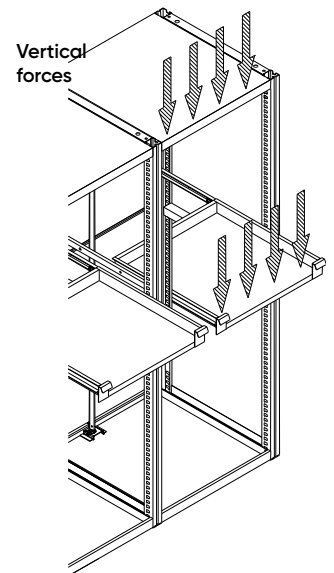

Fig. 1

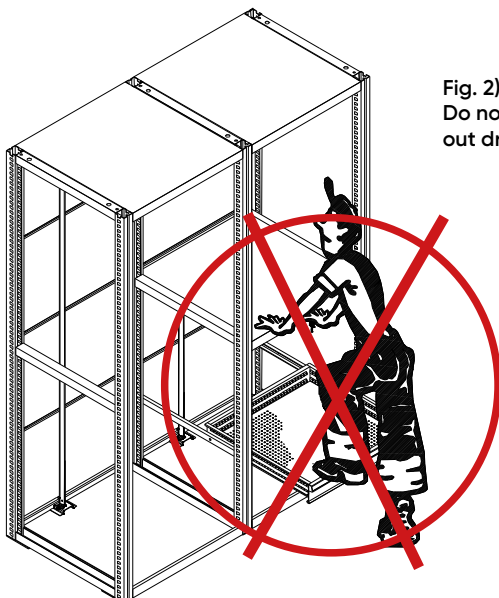

Fig. 2)
Do not climb onto the pull-out drawers or shelves

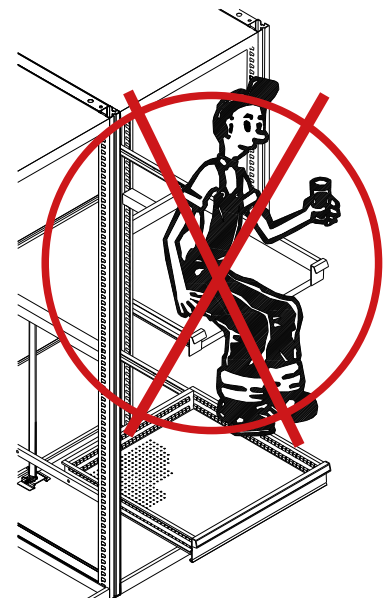

Fig. 3)
Do not sit on the pull-out drawers or shelves

IMPORTANT

Fami guarantees the effectiveness of the mounting set **Art. F SR 8999 00 99** only if, further to these instructions, stability regulations are observed, which require the adoption for each rack unit of **1 rod** for the individual opening of the pull-out shelf or drawer and require that the user open only one pull-out shelf or drawer per unit at a time.

FAMI, pursuant to Directive 92/59/EEC, prohibits the use of the racks if:

- The floor is not conforming to specifications or is cracked or damaged in any way (p. 22).
- The components of the rack are damaged or faulty.
- The rack is not fully anchored to the floor or wall.
- The floor anchors or mounting bolts are not properly installed.
- The rack is not properly assembled.
- **The load capacity labels on the pull-out or fixed shelves or the general load capacity tables are missing**

SAFETY: DEFINITION OF THE TERM "OPERATOR"**Definition of the term "operator"**

The following terms are defined as follows:

- Maintenance staff: persons charged with installing, repairing and servicing the racks.
- A qualified person who has completed specialised training as a mechanic.
- User: persons using the racks. They must observe the user instructions given in page 24.

Such persons may not do any work other than that indicated on page 24. The user may not service the racks. Before working with or on the racks, the operator must be familiar with them and have read and understood this manual.

SAFETY

In order to assure the health and safety of the operators, the racks are equipped with the following passive safety equipment:

- Footholds for anchoring the racks to the floor and to distribute the load.
- Stability system (only one pull-out shelf or drawer may be opened at a time).
- **Load capacity as indicated in the catalogue, on page 1329 onwards** (<https://famispafamicdn.com/wp-content/uploads/doc/scaffalature-componibile-SRmaster-IT.pdf>).
- **Load capacity labels on the fixed and pull-out shelves.**

The employer must thoroughly inform all operators about risks and hazards, especially as regards PPE and the safety regulations provided by the law or international and local standards. All operators must observe said regulations and standards. Do not tamper with, remove, or replace any parts unless expressly authorised by FAMI to do so. Any modification to the racks which is not expressly authorised by FAMI relieves FAMI of any and all civil and penal liability for the consequences.

- ✓ Do not remove or tamper with any safety equipment.
- ✓ All routine and occasional maintenance must be done with the racks empty.
- ✓ Operators must avoid unsafe procedures in inconvenient positions which risk them losing their balance.
- ✓ The workplace must be properly lit.

Residual risk zones

Residual risks are present in some zones of the racks which it was not possible to eliminate during the design or delimit by guards, given the particular function and use of the racks. **Fig. 4** shows these hazards.

- Pull-out shelves and drawers must be opened and closed only with their handles (Ref. **A**).
- Do not insert your fingers into the holes in the vertical frame members (Ref. **B**).
- Do not rub your hands hard against the edges of the vertical frame members (Ref. **C**).
- Do not rub your hands hard against the lower corners of the shelves or drawers (Ref. **D**).
- Do not insert your hands into the gaps between the pull-out shelves or drawers and the vertical frame members. (Ref. **E**).
- Do not insert your hands into the bearing rails. (Ref. **F**).

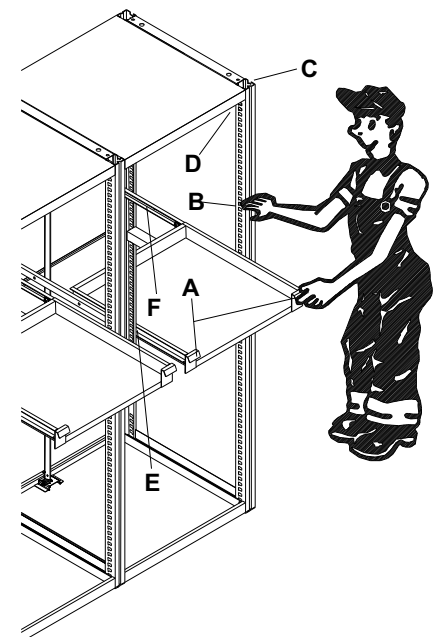
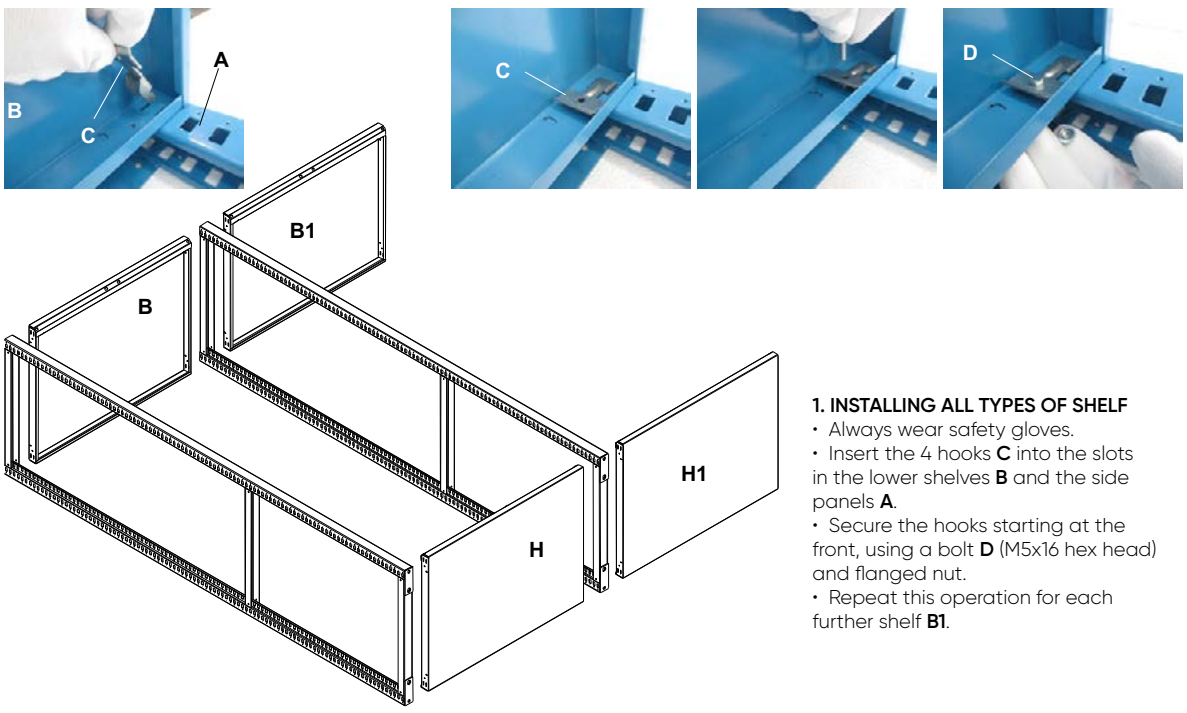

Fig. 4

IMPORTANT

Pay special attention to the residual hazards described on this page. Every user must use PPE including aprons, gloves, safety shoes, etc.. Every time you use the racks, make sure they are fully assembled and in good condition, and only do so in observance of the information given in the chapter "Intended use".

INSTALLING THE VARIOUS TYPES OF SHELF FOR F SR SERIES RACKS



1. INSTALLING ALL TYPES OF SHELF

- Always wear safety gloves.
- Insert the 4 hooks **C** into the slots in the lower shelves **B** and the side panels **A**.
- Secure the hooks starting at the front, using a bolt **D** (M5x16 hex head) and flanged nut.
- Repeat this operation for each further shelf **B1**.

INSTALLING THE DIAGONAL BRACES

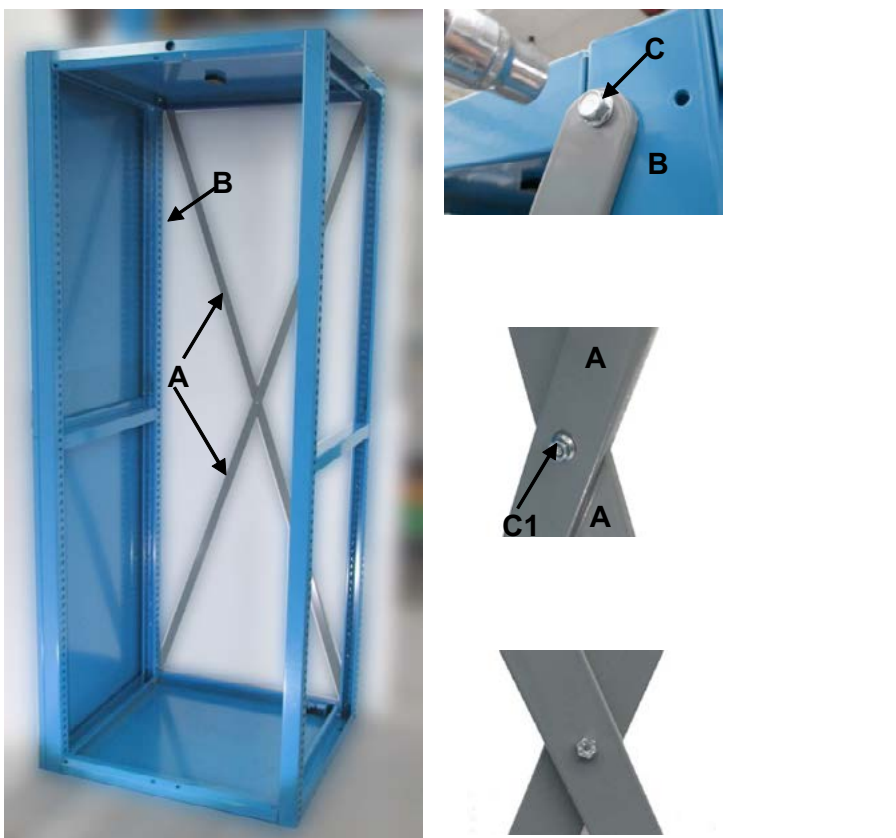

3. INSTALLING THE DIAGONAL BRACES

- Always wear safety gloves.
- Secure component **A** of the brace with 2 bolts **C** (M6.3x19) to the side panel **B** and centrally to each other with 1 bolt **C1** (M5x20 hex head) and flanged nut.

 **A BRACE MUST BE INSTALLED AT LEAST EVERY 3 UNITS**

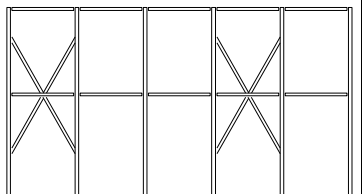

INSTALLING THE BACK PANELS

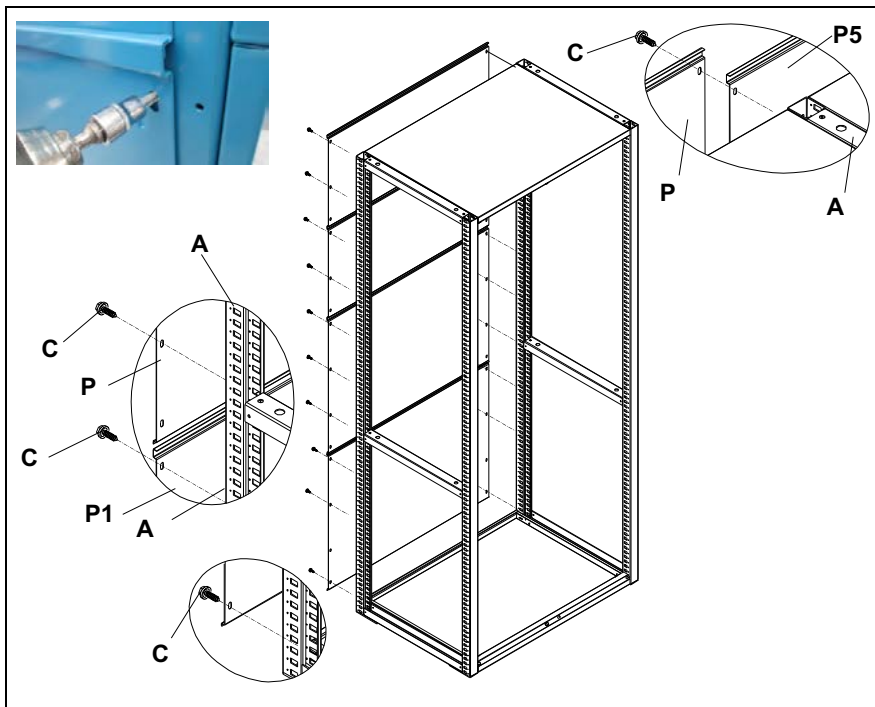

1. INSTALLING THE BACK PANELS

- Always wear safety gloves.
- Secure the back panels P starting from the top, using bolts C (M6.3x19).
- Then install panel P1 and the others to the side panel.

Caution:

- The panels used to cover the rack units may be of different heights; make sure that the sum of their heights is equal to the total height of the vertical frame members before proceeding.

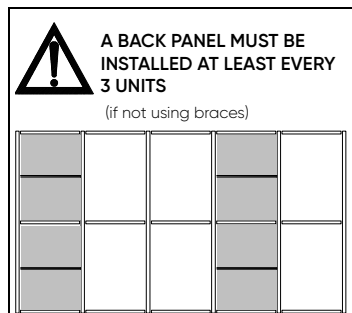

INSTALLING THE SIDE PANELS

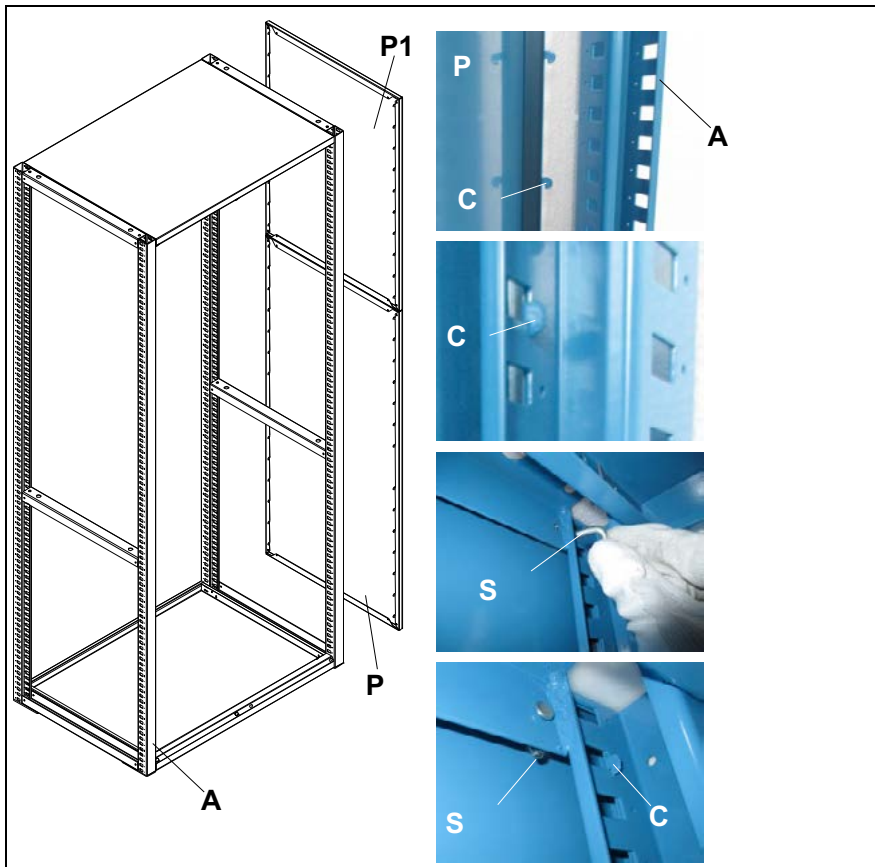

1. INSTALLING THE SIDE PANELS

- Always wear safety gloves.
 - Install the side panels P starting from the bottom.
- Hook the panel P to the side A, using the provided hooks C in the wall panel.
- Repeat the operation for the top side panel P1.
 - Secure the top side panel with the studs S on its back and front.

Caution is required when installing:

- 1 side wall for the side up to 1510 mm height
- 2 side walls for the side 2010/3010 mm height

The panels used to cover the side may be of different heights; make sure that the sum of their heights is equal to the total height of the side before proceeding.

INSTALLING THE BACKBONE

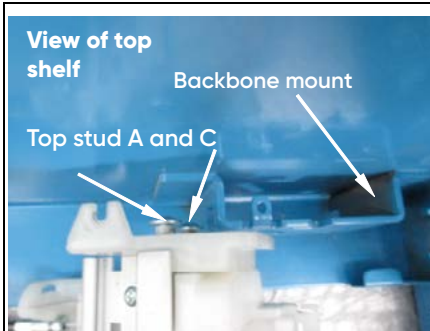
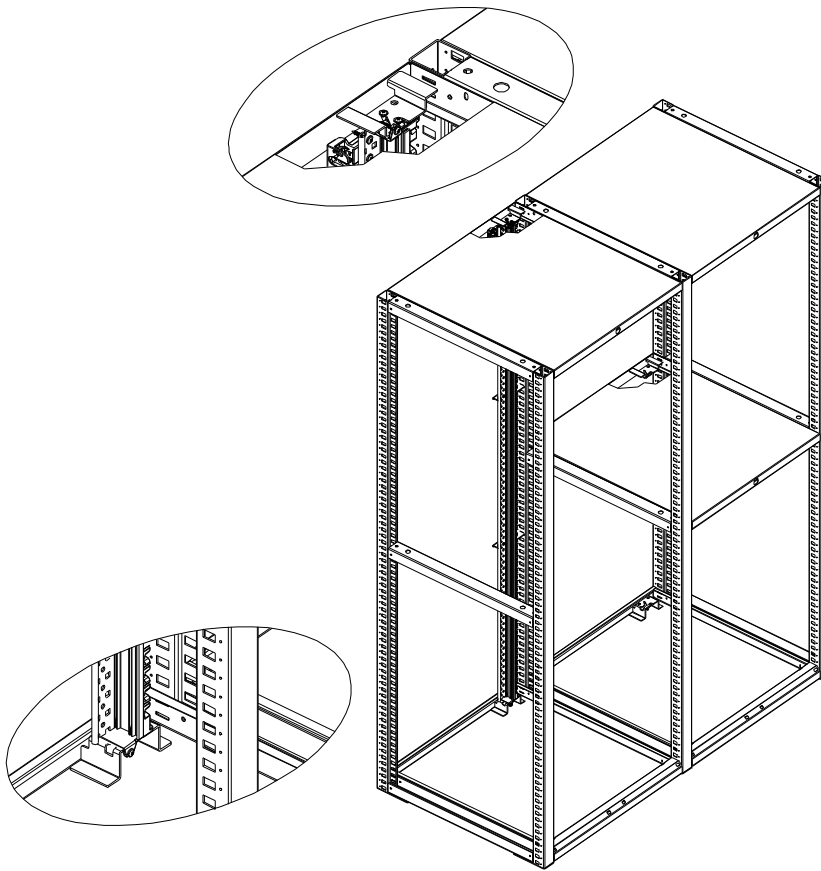

Insert top stud **A** and lower stud **B** into their slots at the same time.

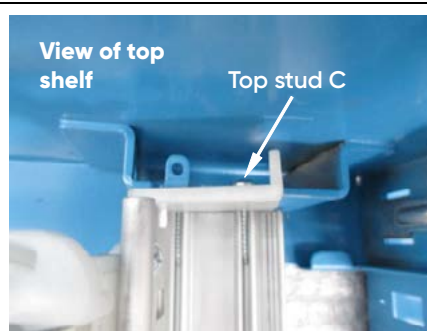

Rotate the backbone counterclockwise and clockwise until it is resting on the backbone mount at the slots so that studs **C** and **D** are aligned.



Secure the backbone to the top and bottom mounts with 2 self-tapping screws (3.9x25 round dome head).

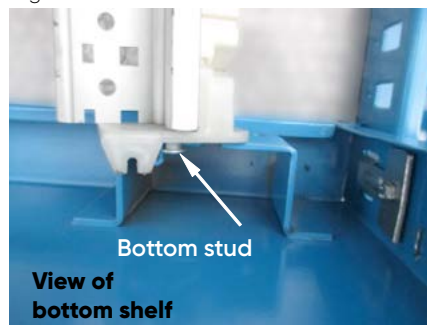
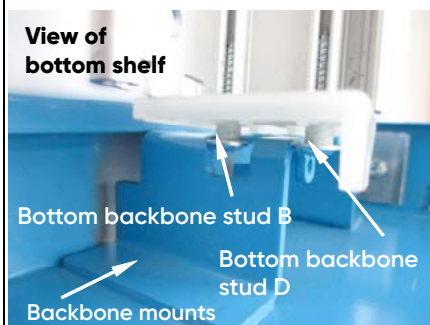

MECHANICAL CABINET CLOSURE ASSEMBLY

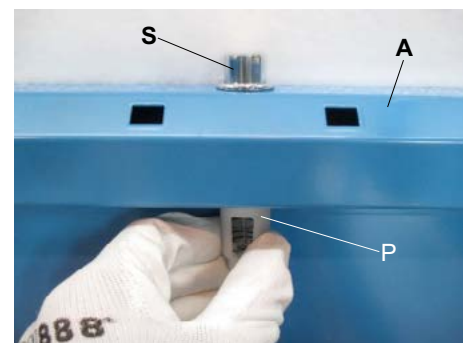
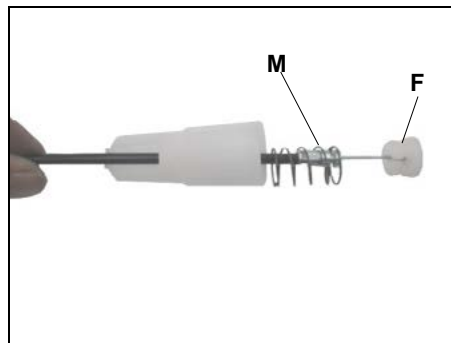
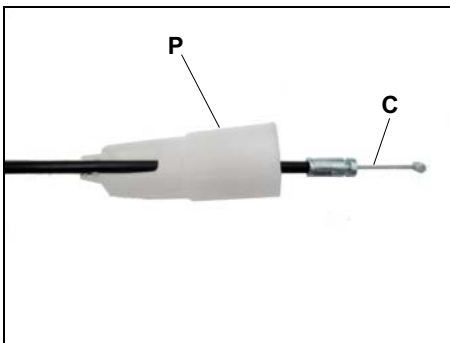
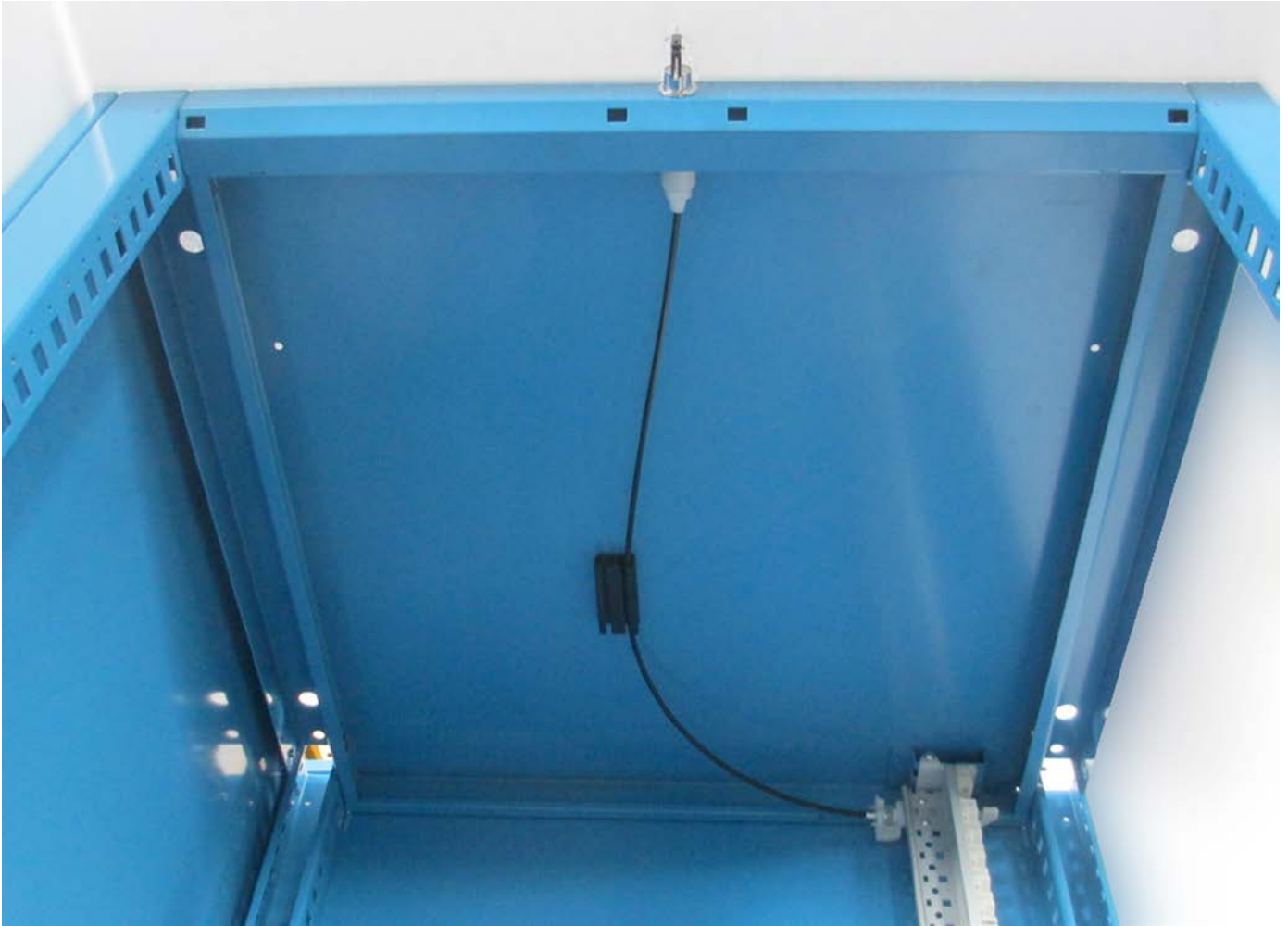

Screw the lock assembly **S** into the top shelf for the lock **A** and the sleeve **P**.

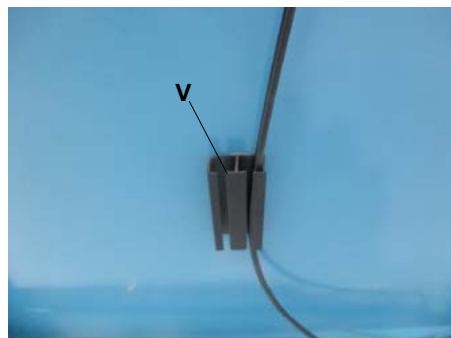
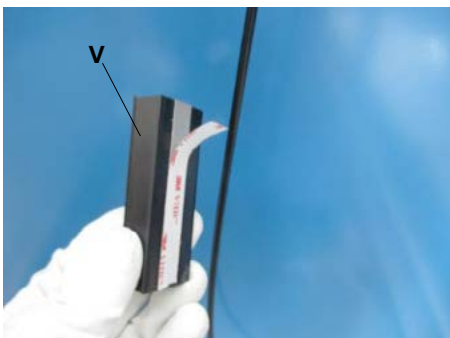

Sand the area for gluing with fine grain sandpaper. Clean with a dry cloth. Remove the protective strip from the bi-adhesive tape in the cable duct profile **V** and then secure it, taking care that the bend is not too sharp (see photo).

View of cable duct profile **V** with cable inserted.

INSTALLING THE FLEXIBLE PULL-OUT RAILS

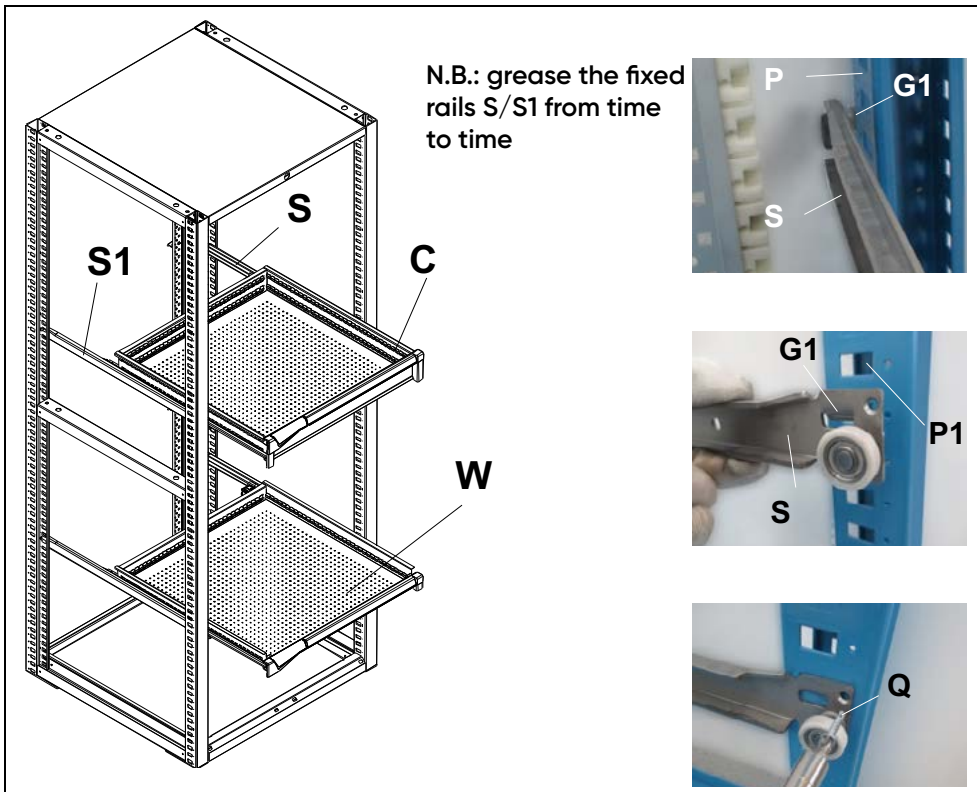

INSTALLING THE TELESCOPIC PULL-OUT RAILS

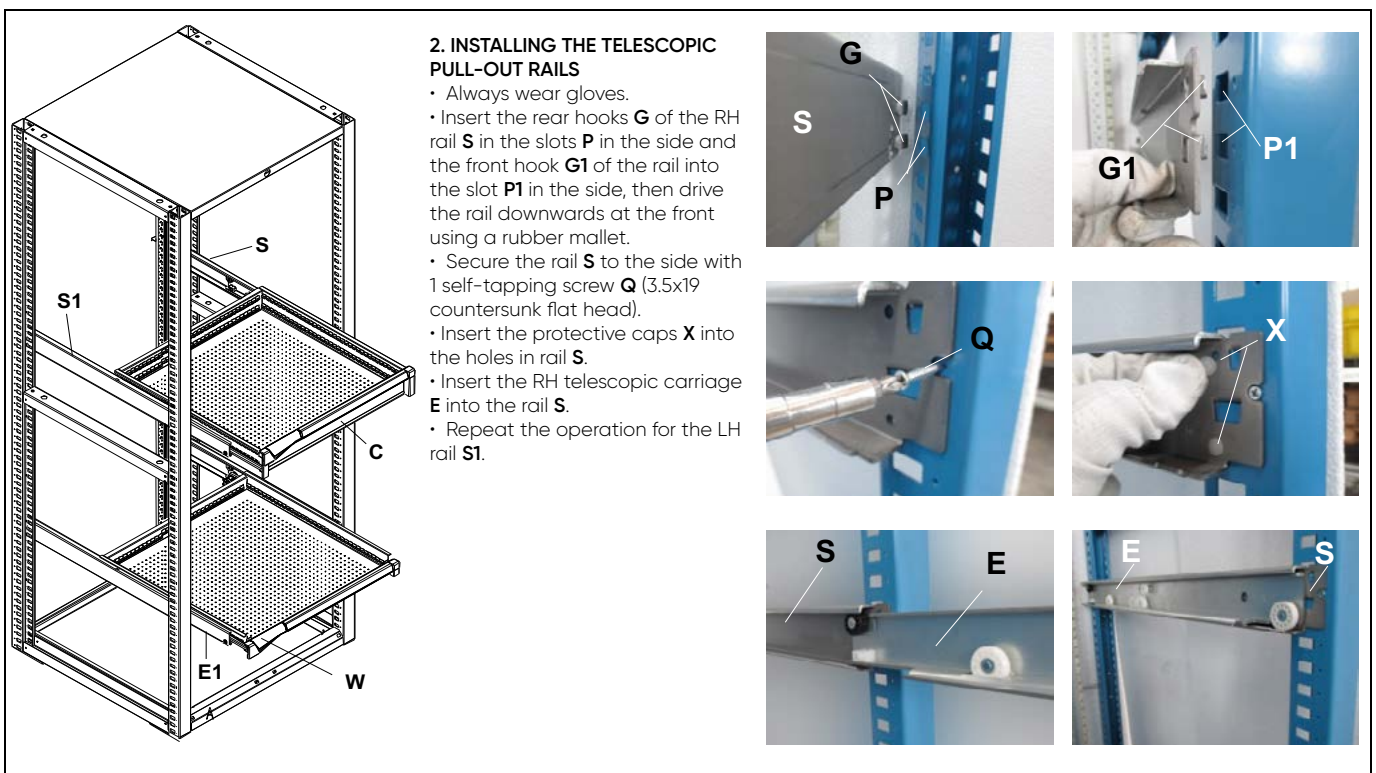

INSTALLING THE BACKBONE SPRINGS



INSTALLING THE BACKBONE SPRINGS

Always wear protective gloves.
Install the backbone springs H starting from the bottom.
Locate the spring H next to each drawer rail G.
Insert the spring H into the square hole Q, then secure it by applying light pressure on its head T so that it locates in the rectangular hole K.
Repeat for each drawer rail.

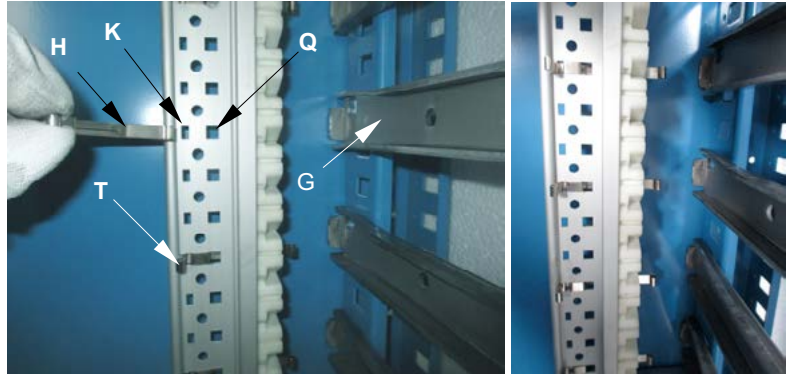

DISASSEMBLING THE PULL-OUT DRAWERS AND SHELVES

Always wear protective gloves.
Disassemble the drawers **starting from the bottom**

SIDE TORSION BRACKET

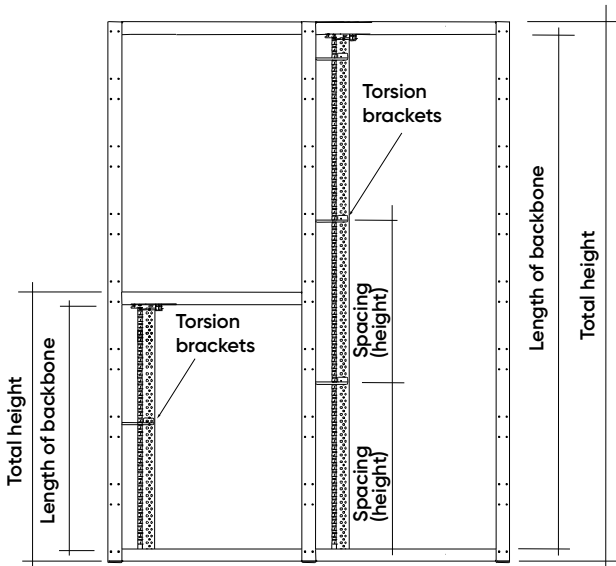

The side torsion brackets F must be located at fixed heights relative to the positions of the pull-out drawer/shelf rails and in an adequate number.

| Total height mm | Total length mm | Number of torsion brackets G | Spacing (height) |
|-----------------|-----------------|------------------------------|------------------|
| 400 | 329 | 0 | - |
| 600 | 529 | 0 | - |
| 700 | 629 | 0 | - |
| 800 | 729 | 1 | 390 mm |
| 850 | 779 | 1 | 390 mm |
| 900 | 829 | 1 | 390 mm |
| 1000 | 929 | 1 | 465 mm |
| 1150 | 1079 | 2 | 365 mm |
| 1325 | 1254 | 2 | 415 mm |
| 1500 | 1429 | 2 | 465 mm |
| 1625 | 1554 | 2 | 515 mm |
| 2000 | 1929 | 3 | 640 mm |
| 2200 | 2129 | 4 | 540 mm |
| 2500 | 2429 | 4 | 615 mm |
| 3000 | 2929 | 5 | 590 mm |

INSTALLING THE SIDE TORSION BRACKET

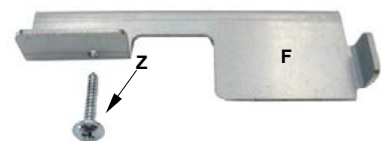

Secure the torsion brackets with 1 round dome head self-tapping screw (3.9x25) Z as shown in the table above.

N.B.: Insert the drawers C or pull-out shelves W into the rails S/S1 only after having installed the backbone springs and torsion brackets, starting from the top

BACKBONE HEIGHT SHIM

For backbone rod lengths greater than 1000mm, the height of the backbone must be adjusted with shims, **CODE X2139913**, at the positions shown in the drawing or after the number of backbones indicated in the table.

Make sure to check that the backbone rod is working properly.

If two drawers open together, adjust the penultimate backbone of the upper drawer.

| N. BACKBONES | HEIGHT H |
|--------------|----------|
| 37 | 940 mm |
| 50 | 1270 mm |
| 67 | 1702 mm |

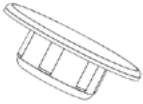

X2139913 LOW FRICTION CAP Ø 9 IN PE-HD MP 90 NATURAL

| PART CODE | DESCRIPTION | N. SHIMS |
|----------------|--|----------|
| M00V0200000000 | MASTER BACKBONE ROD - DIM. H = 229 MM | 0 |
| M00V0300000000 | MASTER BACKBONE ROD - DIM. H = 329 MM | 0 |
| M00V0500000000 | MASTER BACKBONE ROD - DIM. H = 529 MM | 0 |
| M00V0600000000 | MASTER BACKBONE ROD - DIM. H = 629 MM | 0 |
| M00V0700000000 | MASTER BACKBONE ROD - DIM. H = 729 MM | 0 |
| M00V0720000000 | MASTER BACKBONE ROD - DIM. H = 754 MM | 0 |
| M00V0750000000 | MASTER BACKBONE ROD - DIM. H = 779 MM | 0 |
| M00V0900000000 | MASTER BACKBONE ROD - DIM. H = 929 MM | 0 |
| M00V1050000000 | MASTER BACKBONE ROD - DIM. H = 1079 MM | 1 |
| M00V1220000000 | MASTER BACKBONE ROD - DIM. H = 1254 MM | 1 |
| M00V1400000000 | MASTER BACKBONE ROD - DIM. H = 1429 MM | 2 |
| M00V1520000000 | MASTER BACKBONE ROD - DIM. H = 1554 MM | 2 |
| M00V1900000000 | MASTER BACKBONE ROD - DIM. H = 1929 MM | 2 |

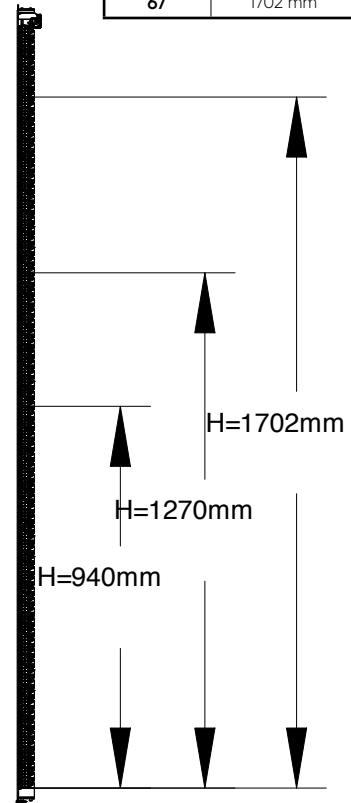

1

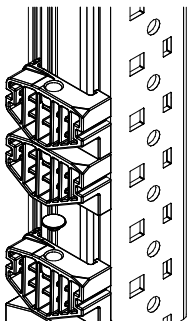

2

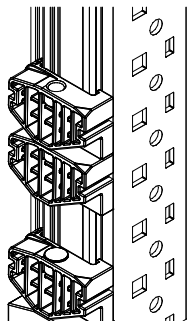

3

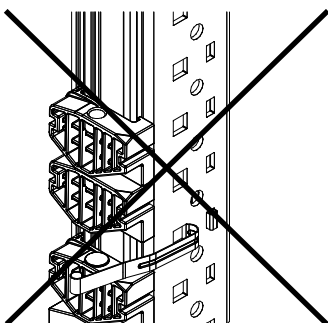
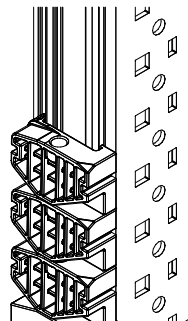

DO NOT fit shims next to drawer springs. If the heights are the same, fit the cap onto the lower backbone rod

ADJUSTING THE PULL AND CAPACITY OF THE DRAWERS



1. Modifying the pull and load capacity of the flexible pull-out drawers

- Always wear safety gloves.
- Insert the load adjuster stop into the same position on both sides, as shown in the images.

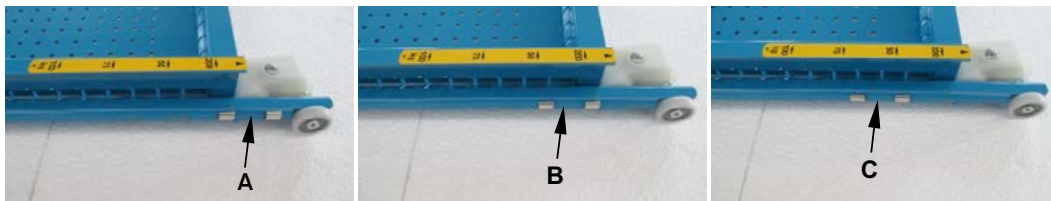

A Position A = pull 100%
capacity 50 kg

B Position B = pull 96%
capacity 75 kg

C Position C = pull 92%
capacity 100 kg



Flexible pull-out drawers 50 kg / 75 kg / 100 kg



Telescopic pull-out
drawers 200 kg

DISASSEMBLING THE DRAWER PLASTIC PARTS KIT



1. DISASSEMBLING THE DRAWER PLASTIC PARTS KIT

- Always wear safety gloves.
- Insert the screwdriver into the hole in the drawer to extract the LH handle.
- Extract the card holder F and the RH side cap L.

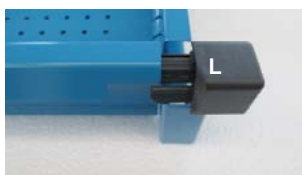

2. INSERTING THE LABELS

Insert the labels into their holders.

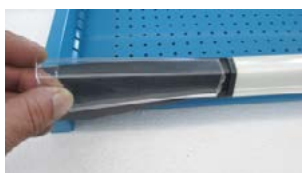
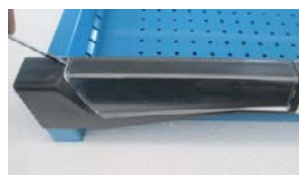

DOOR MOUNTING KIT

| | | | | | | | | | | | | | | |
|---|--|---|-------------------------------------|---|-------------------------------------|-------------------------------------|--|--------------------------------|--|-------------------------------------|---|---------------------------------------|--|-------------------------------------|
| <p>Cabinet hinge FRH</p> | <table border="0"> <tr> <td data-bbox="464 315 727 501"> <p>Cabinet hinge FRH</p> </td> <td data-bbox="764 315 1027 501"> <p>Cabinet hinge FLH</p> </td> <td data-bbox="1011 421 1139 663"> <p>Flat head self-tapping screws (3.5x19) Q.</p> </td> </tr> <tr> <td data-bbox="464 568 727 754"> <p>Cabinet hinge FLH</p> </td> <td data-bbox="764 568 1027 754"> <p>Cabinet hinge FRH</p> </td> <td></td> </tr> <tr> <td data-bbox="464 792 632 927"> <p>Hinge pins L</p> </td> <td data-bbox="668 927 868 1173"> <p>Threaded inserts X</p> </td> <td data-bbox="979 770 1091 972"> <p>Door panels P</p> </td> </tr> <tr> <td data-bbox="493 972 604 1173"> <p>Button head screw with hex socket (M5x16) V</p> </td> <td data-bbox="908 994 1099 1218"> <p>Plastic hinge cap K</p> </td> <td></td> </tr> </table> | <p>Cabinet hinge FRH</p> | <p>Cabinet hinge FLH</p> | <p>Flat head self-tapping screws (3.5x19) Q.</p> | <p>Cabinet hinge FLH</p> | <p>Cabinet hinge FRH</p> | | <p>Hinge pins L</p> | <p>Threaded inserts X</p> | <p>Door panels P</p> | <p>Button head screw with hex socket (M5x16) V</p> | <p>Plastic hinge cap K</p> | | <p>Cabinet hinge FLH</p> |
| <p>Cabinet hinge FRH</p> | <p>Cabinet hinge FLH</p> | <p>Flat head self-tapping screws (3.5x19) Q.</p> | | | | | | | | | | | | |
| <p>Cabinet hinge FLH</p> | <p>Cabinet hinge FRH</p> | | | | | | | | | | | | | |
| <p>Hinge pins L</p> | <p>Threaded inserts X</p> | <p>Door panels P</p> | | | | | | | | | | | | |
| <p>Button head screw with hex socket (M5x16) V</p> | <p>Plastic hinge cap K</p> | | | | | | | | | | | | | |
| <p>Cabinet hinge FLH</p> | <p>Cabinet hinge FRH</p> | | | | | | | | | | | | | |



ASSEMBLING THE SINGLE RH/LH DOOR OR DOUBLE DOORS

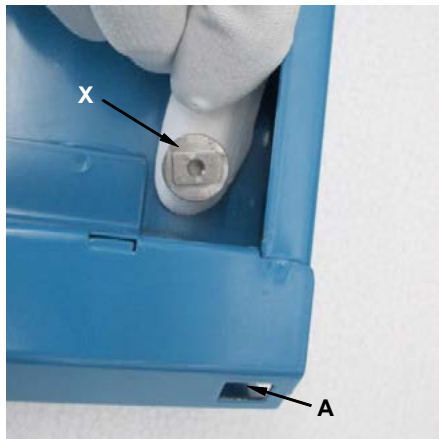

Insert a threaded insert **X**, so that the rectangular part coincides with the slot **A** in the top or bottom shelf.

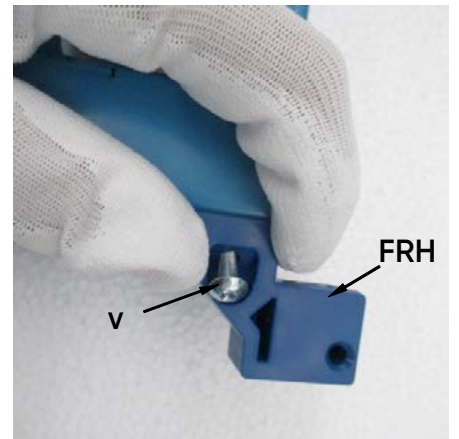
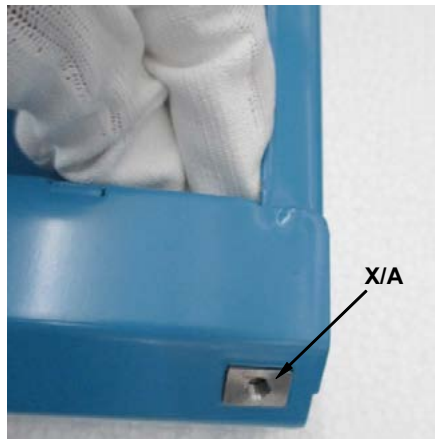

Secure the hinge the cabinet **FRH** with a button head screw with hex socket **V** (M5x16) in the insert **X**.

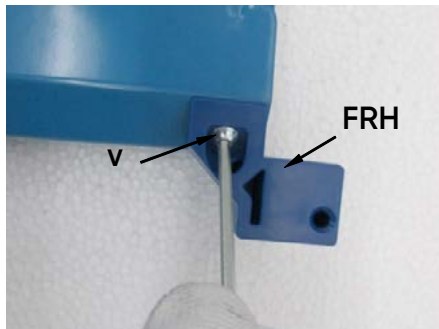

Repeat the operation for the insert **FLH** and the top shelf.

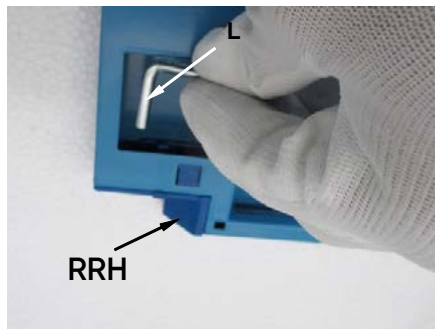

Insert the hinge pin **L** into the bottom hinge hole **RRH** for the right door

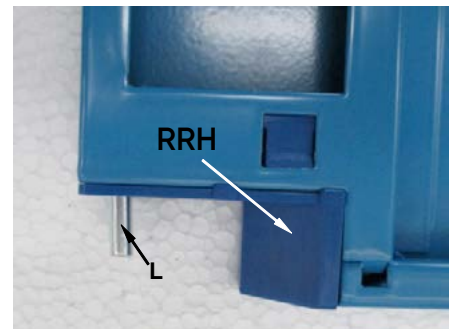

Repeat for the LH door.

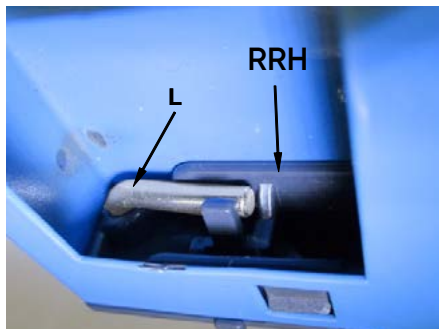

Press the hinge pin **L** so that it is held by its clips. Repeat for the LH door.

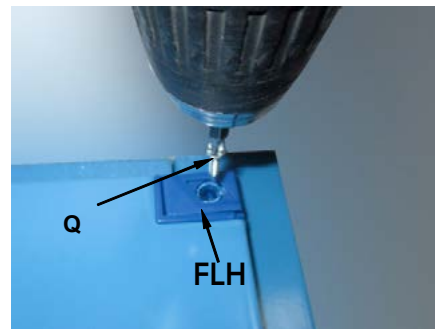

Secure the hinge **FRH** at the bottom and **FLH** at the top to the side with 1 self-tapping screw **Q** (3.5x19 countersunk flat head).

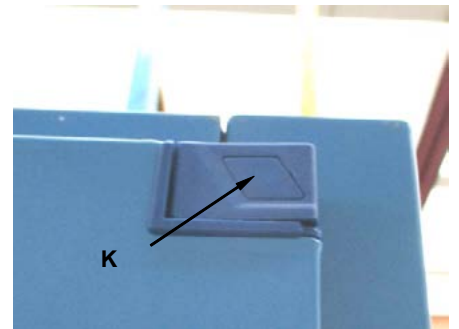

Fit the plastic caps **K**.

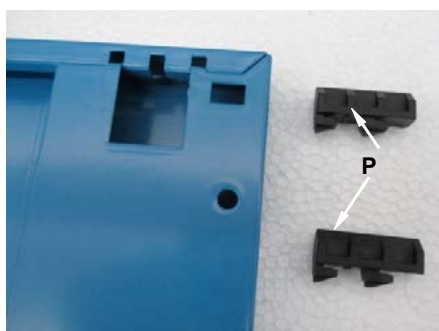

Double door configuration

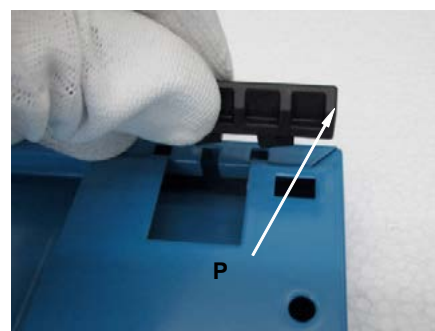

In the double door configuration, insert the door panels **P** in black plastic into both the top and bottom of the LH door.

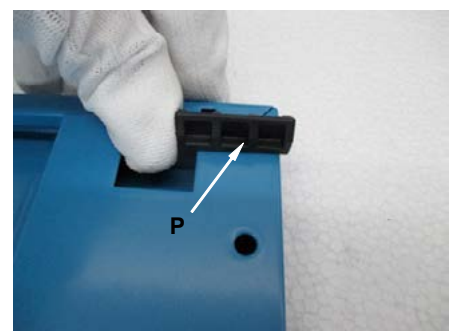

**EXAMPLE OF ELECTRONIC LOCK CABLING FOR F SR SERIES RACK (2000 mm h)
WITH FULL HEIGHT DRAWERS**

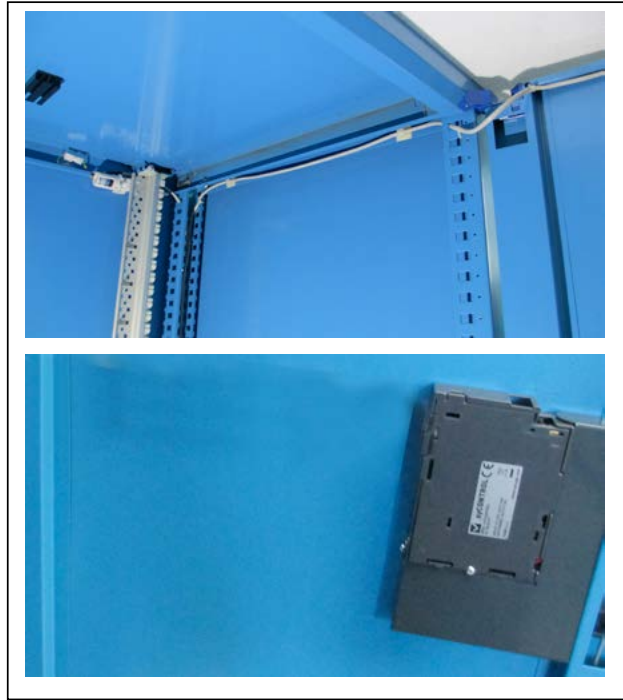

N.B.: Make sure to leave a gap of 75 mm to route the cables.



Battery replacement procedure

**EXAMPLE OF ELECTRONIC LOCK CABLING FOR F SR SERIES RACK (2000 mm h)
WITH PARTIAL HEIGHT DRAWERS**

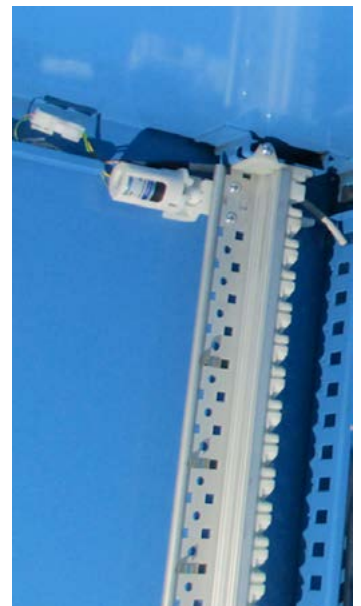

SLIDING DOORS FOR FSR RACKS

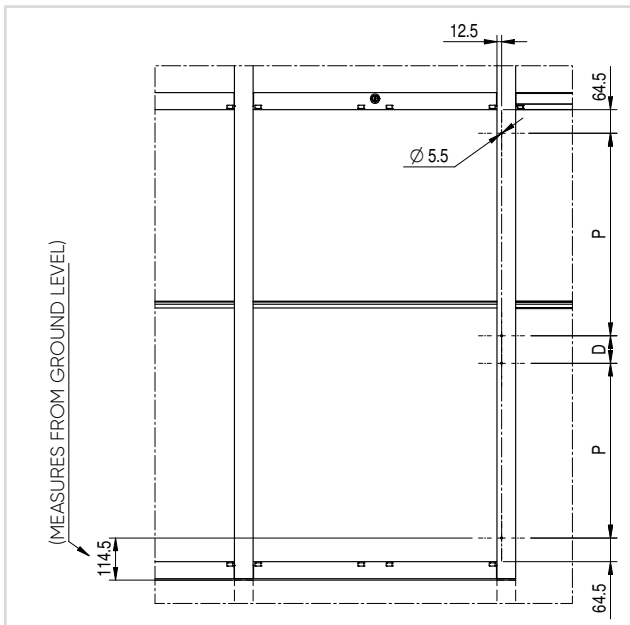

MEASURES REFERRED TO THE SHELF WITH UPPER/LOWER LOCK OR SEAL SHELF

| ARTICLE | P | D |
|--------------------|---------|---------|
| M 30 P075 C0 00 21 | NO HOLE | +2P=625 |
| M 30 P090 C0 00 21 | 375 | 25 |
| M 30 P140 C0 00 21 | 575 | 125 |
| M 30 P190 C0 00 21 | 575 | 625 |
| M 30 P075 C0 00 31 | NO HOLE | +2P=625 |
| M 30 P090 C0 00 31 | 375 | 25 |
| M 30 P140 C0 00 31 | 575 | 125 |
| M 30 P190 C0 00 31 | 575 | 625 |
| M 30 P240 C0 00 31 | 775 | 1500 |

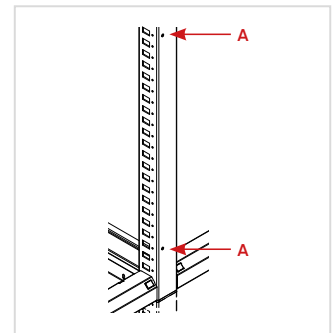

View of an FSR rack with sliding doors



CHECK THAT THE RACK IS LEVEL

COMPONENTS

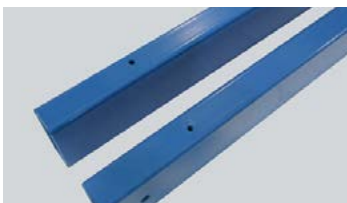

Pair of side pads for sliding doors.

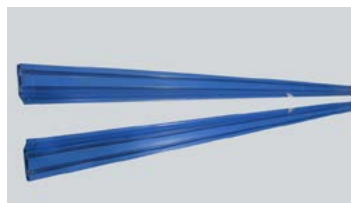

Pair of rails for sliding doors.



Pair of RH/LH caps.



X 8

Side pad mounting screws for F SR racks.
M5 x 20 cylinder head hex socket



X 8

Master cabinet side pad mounting screws
M5 x 60 cylinder head hex socket



X 12



X 12

Bottom/top cross member mounting screws
Button head screw with hex socket (M5x12)
Square inserts with M5 thread

INSTALLING THE SLIDING DOOR



Insert the inserts with M5 threaded square section in the 4 seats of the bottom rack shelf

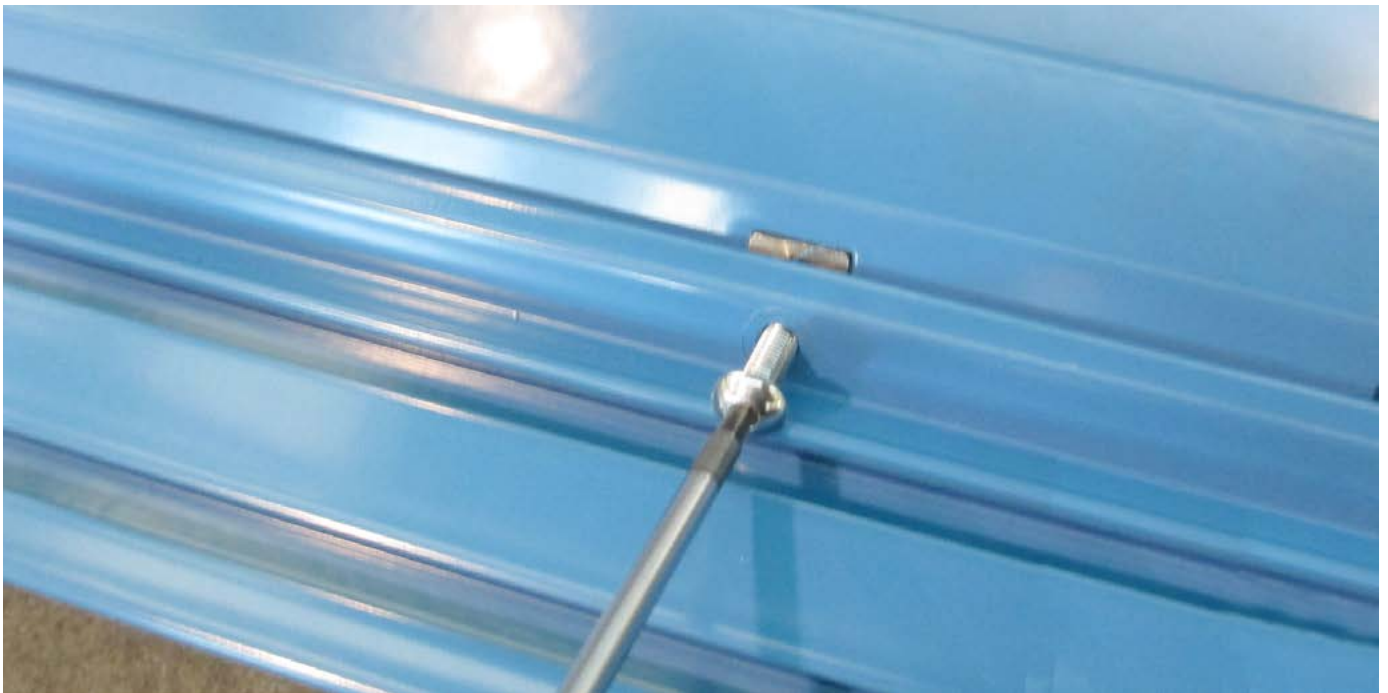

Secure the rail to the top and bottom shelves with the 4 button head hex socket screws (M5x12)



View of rail mounted to the rack



F SR series racks

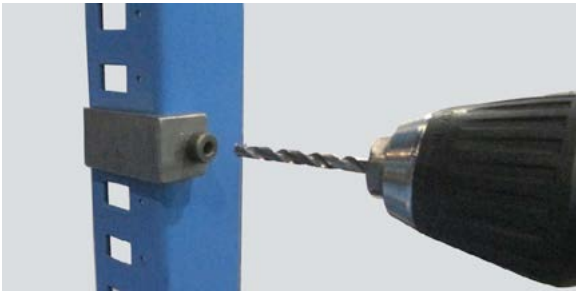

Use a 5.5 tip to drill the side panel with a template to observe the pitch or measurements given in page 15 **letter A**

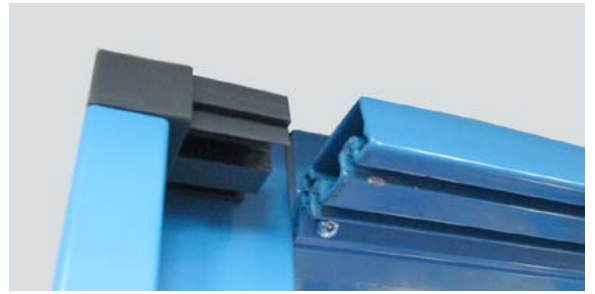

Insert the cap into the top of the pad.

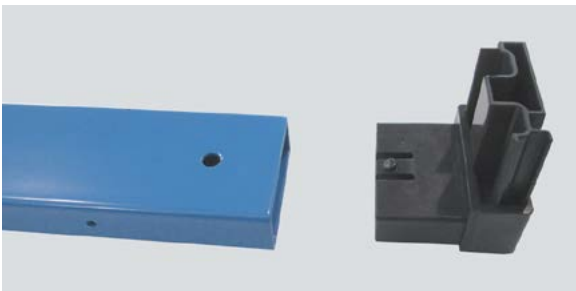

Inserting the cap.



Insert the cap into the bottom of the pad.

Inserting the LH sliding door



Secure the pad to the side with the **cylinder head hex socket screws (M5 x 20)**.



Insert the door wheels with bearings into the top rail.



Insert the door wheels with bearings into the bottom of the LH door and secure them with M6 locknuts.

Inserting the RH sliding door



Insert the door wheels with bearings into the outer top rail. Insert the door wheels with bearings into the bottom of the LH door and secure them with M6 locknuts.



Insert the door stop into the slots in the bottom and top of the RH door.

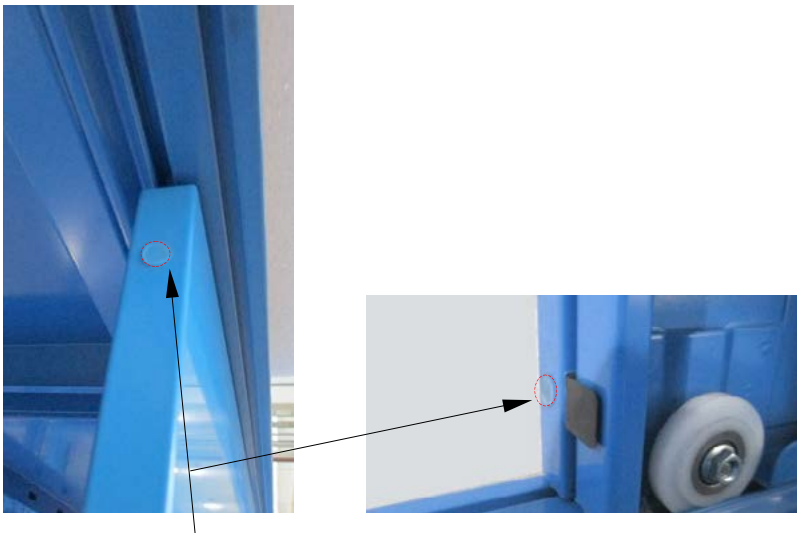

Apply the transparent adhesive rubber blocks at the top and bottom of the sliding doors.

SHUTTER DOOR FOR FSR RACKS



Complete view of an FSR rack with shutter doors



SHUTTER DOOR BLOCK

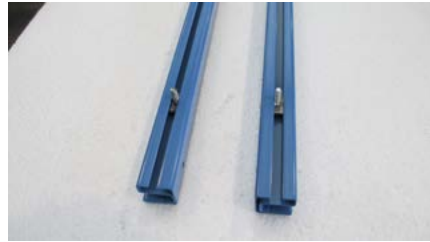

SHUTTER DOOR RAILS

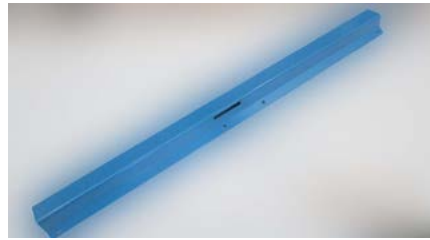

LOWER SHUTTER DOOR CROSS MEMBER



X 4

Shutter door block mounting screws

4 dome head hex key screws
M6x20



X 8



X 8

Shutter door rail mounting plates

8 plates with self-locking M5 threaded
grubscrew and flanged M5 nuts.



X 3



X 3

Bottom cross member mounting screws

3 dome head hex key screws (M5x10) and 3 M5
inserts with square threaded section.

INSTALLING THE SHUTTER DOOR TO FSR RACKS



Insert the inserts with M5 threaded square section in the 3 seats of the bottom rack shelf



Secure the shutter door cross member to the bottom shelf with the 3 dome head hex screws (M5x10)



Drill the sides with a 5.5 mm tip (see table) to mount the shutter door rails.



Partially secure the 8 plates with grub screws and M5 flanged nuts to the side. Insert the shutter door rails into the plates

F SR series racks



Tighten the rails fully down onto the sides.



Insert the shutter door block into the top of the rack.

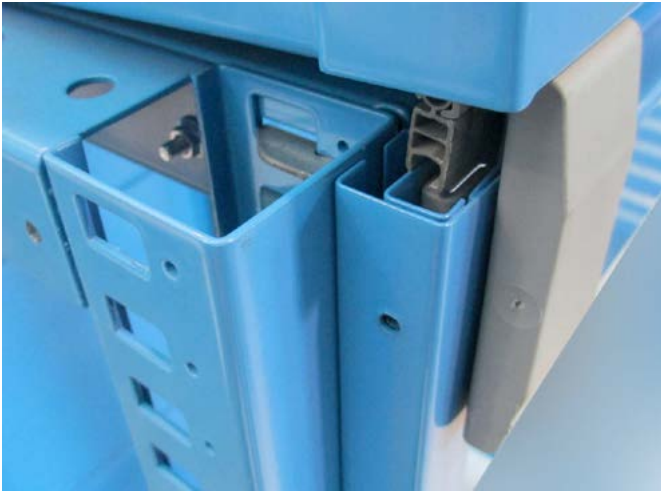

Insert the shutter door block into the rails at the top of the rack.



secure the shutter door block to the top shelf of the rack with the 4 dome head hex key M6x20 screws.



View of closed shutter door.

RECOMMENDATIONS FOR INSTALLATION

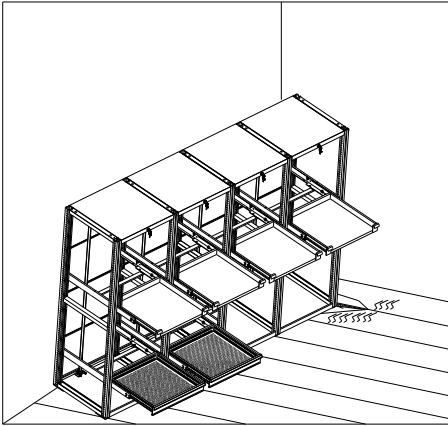

The rack must be installed on a floor capable of bearing the total weight of the rack and its contents. To calculate the suitability of the floor to bear the weight of the rack, see page 23.

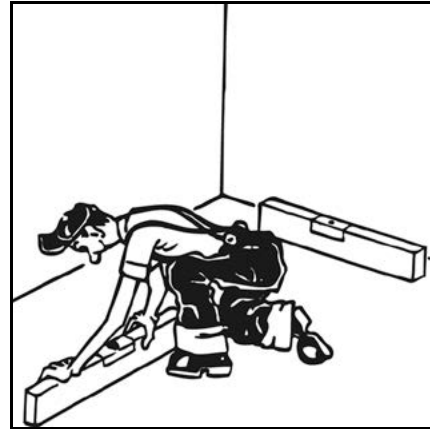

The floor must be perfectly level.

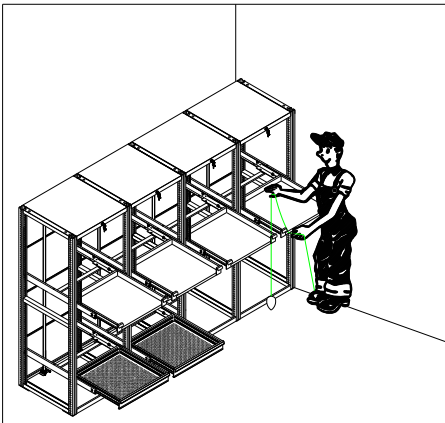

The rack must be perfectly vertical.

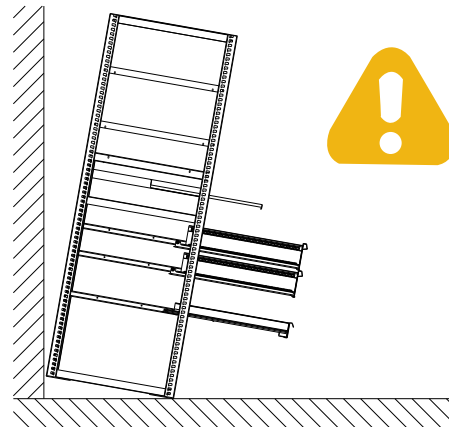

Secure the rack to the floor as explained on page 23.

FLOOR MOUNTING

Characteristics of the floor mounting kit: 2 anchor bolts for crack-free concrete floors \geq class $f_{ck,cube} = 25 \text{ N/mm}^2$

| | |
|--|---------------------|
| Recommended anchor bolt traction: | 5,6 kN |
| Anchor bolt diameter: | Ø 10 mm |
| Installation hole diameter: | Ø 10 mm |
| Minimum depth of hole | h1: 70 mm |
| Minimum installation depth | hnom: 50 mm |
| Maximum mounting thickness | tfix: 20 mm |
| Maximum torque | Tinst: 25 Nm |
| Minimum thickness of floor relative to the mounting of the anchor bolt * | H: 100 mm |

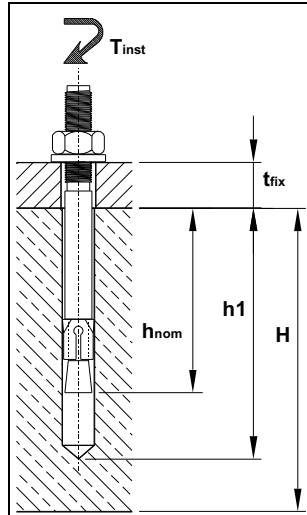

Anchor bolt installation instructions

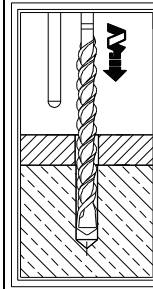

Step 1:
drill the hole with a suitable drill bit

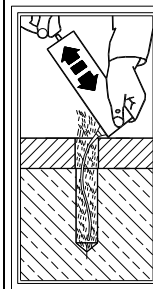

Step 2:
blow the hole out thoroughly

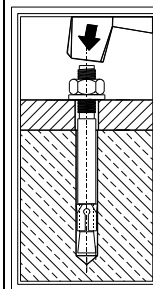

Step 3:
insert the bolt (use a hammer)

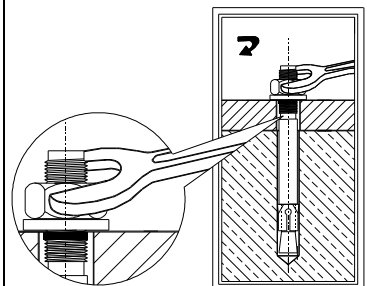

Step 4:
Secure to the Tinst value

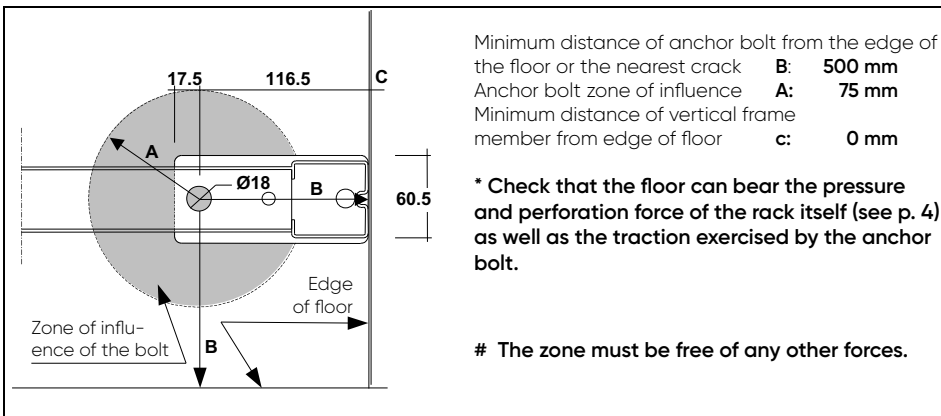

If after installation the coloured check ring is visible, the bolt has not been installed properly and the load may not be applied.

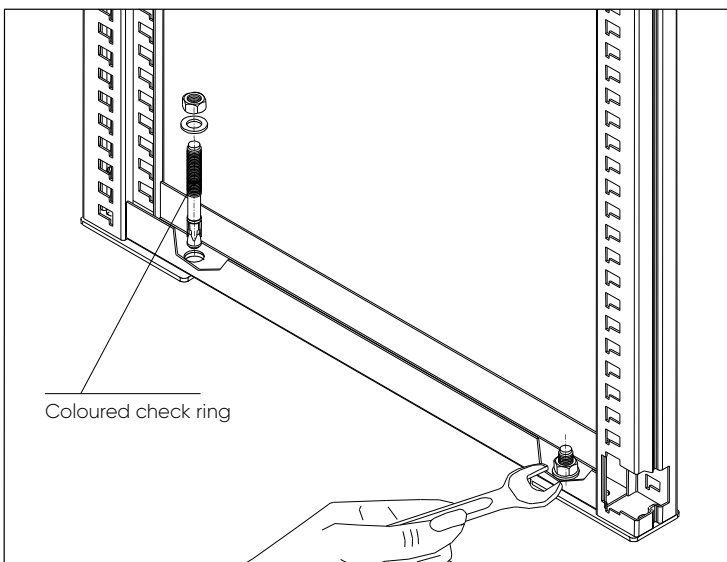

USING THE RACKS

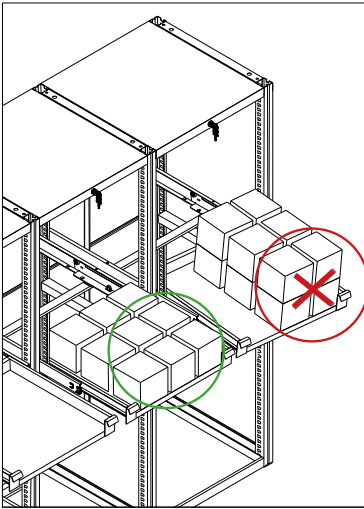

1. LOAD DISTRIBUTION

The fixed and pull-out shelf and drawer capacity values refer to an evenly distributed load.

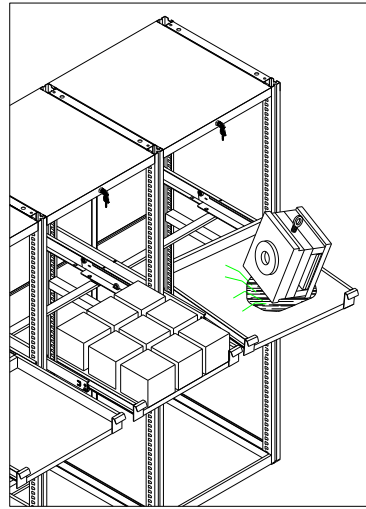

2. LOADING THE MATERIAL

- Read the fixed and pull-out shelf and drawer capacity table carefully before loading the material. If the table is dirty and illegible, see the instructions given under "Maintenance".
- Place the material gently onto the fixed and pull-out shelves and drawers.
- Make sure the material does not protrude beyond the envelope of the fixed and pull-out shelves and drawers.
- Check that the rack is undamaged before using it (deformed frame, large areas of rust, dents).

MAINTENANCE

- Every 6 months, check that the fasteners (bolts and nuts) are fully tightened down.
- Every 6 months, lubricate the pull-out fixed and pull-out shelf and drawer bearings.
- Clean the capacity tables when they are dirty, using non-petroleum solvents with a low alcohol content.
- Whenever you use the racks, check that it is in good working order.

IMPORTANT

Fami guarantees the effectiveness of the mounting set Art. F SR 8999 00 99 only if, further to these instructions, stability regulations are observed, which require the adoption for each rack unit of 1 rod for the individual opening of the pull-out shelf and the locking hook for each pull-out shelf, and require that the user open only one pull-out shelf per unit at a time.

FAMI, pursuant to Directive 92/59/EEC, prohibits the use of the racks if:

- The floor is not conforming to the above specifications or is cracked or damaged in any way.
- The components of the rack are damaged or faulty.
- The rack is not fully anchored to the floor or wall.
- The floor or wall mounting or fasteners are not properly installed.
- The rack is not properly assembled.

SCRAPPING THE RACKS

Disassemble the parts of the rack in reverse order to the assembly instructions. The racks are made primarily of galvanised or painted steel, plastic and paper. Scrap the materials in observance of local waste management regulations.

A series of 24 horizontal dotted lines spanning the width of the page, providing a guide for handwriting practice.

DATE _____

ORDER _____

CODE OPERATOR _____

SIGNED IN ATTESTATION OF CORRECT ASSEMBLY _____

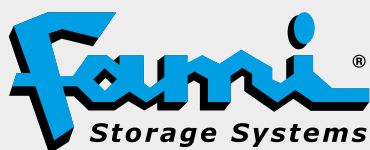

FAMI S.r.l.

Via Stazione Rossano, 13 - 36027 Rosà (Vicenza), Italy

phone: +39 0424 585455 - fax: +39 0424 585470

commerciale@famispa.com

www.famispa.com